



**TAVOLI PIZZA ELITE - VENTILATI TN**  
ELITE PIZZA PREPARATION TABLE - VENTILATED TN  
TABLES DE PREPARATION PIZZA ELITE - VENTILEES TN  
ELITE GEKÜHLTER VORBEREITUNGSTISCH -  
UMLUFTKÜHLUNG TN

**PIZZA  
ELITE  
80**

02/2012 - 00

**IT**

- La linea "Pizzeria" è composta da una vasta gamma di modelli componibili nelle versioni neutra e refrigerata, con profondità di 80 cm., che consentono molte combinazioni in grado di soddisfare, razionalmente, le esigenze di massima funzionalità ed organizzazione del lavoro.
- Gli **elementi** sono interamente costruiti in acciaio inox, pienamente rispondenti alle norme igieniche e montati su piedini regolabili.
- I **piani di lavoro** sono in granito sardo.
- Le **cassettiere** montano di serie guide semplici e sono disponibili in varie versioni, idonee all'alloggio di cassette 70x53, con capacità 20/25 palline per cassetto.
- I **cassetti scorrevoli** dal design pratico e funzionale, montati su guide semplici in acciaio inox, sono facilmente asportabili per una completa e efficace pulizia.
- Gli **elementi** possono essere montati su piedini regolabili inox da 140/190 o 180/230 per un buon livellamento tra gli elementi. A richiesta anche su ruote girevoli inox o zincate.
- Le **vetrinette refrigerate** sono interamente costruite in acciaio inox AISI 304 al Cr-Ni 18/10, complete di vetro di protezione, fianchi laterali, ripiano superiore di appoggio. Adatte per il contenimento di bacinelle Gastronorm in acciaio inox AISI 304 al Cr-Ni 18/10 o in policarbonato, sono dotate di gruppo di funzionamento autonomo.





**TAVOLI PIZZA ELITE - VENTILATI TN**  
ELITE PIZZA PREPARATION TABLE - VENTILATED TN  
TABLES DE PREPARATION PIZZA ELITE - VENTILEES TN  
ELITE GEKÜHLTER VORBEREITUNGSTISCH -  
UMLUFTKÜHLUNG TN

**PIZZA  
ELITE  
80**

02/2012 - 00

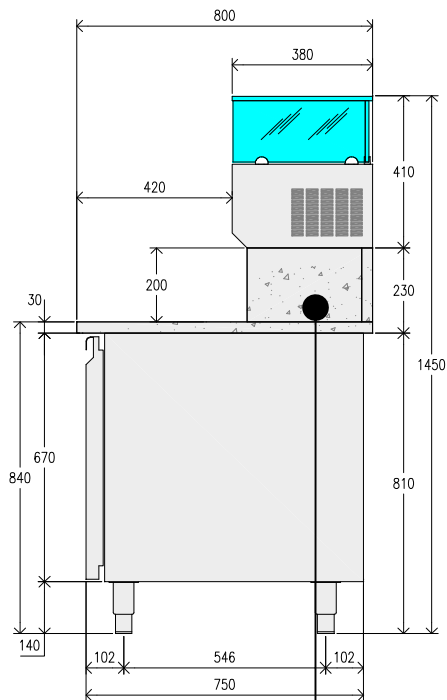

3

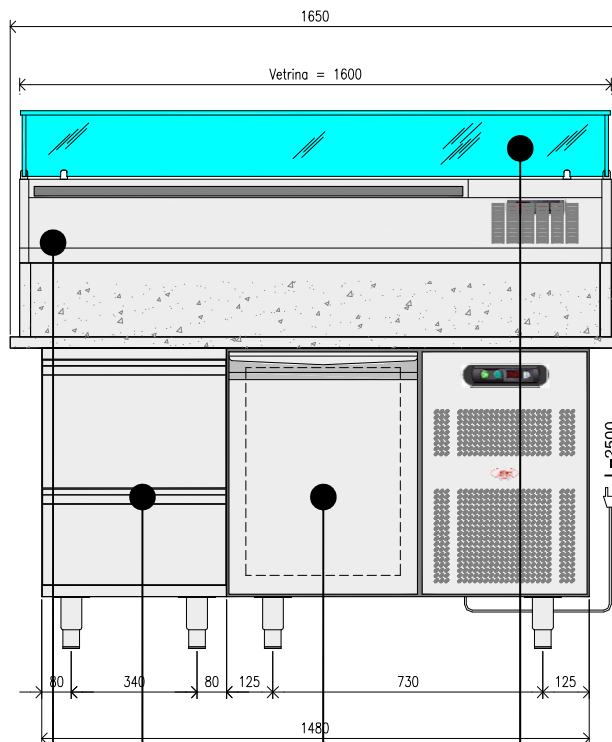

4

2

1

5

BCPZ3014	
1	TRPZ3020
2	CPZ0011
3	PGPZ2055-SI 1650 x 800 x 30 (200)
4	VR381021 1600 x 380
5	KVPC0008

**BCPZ3014 - BANCO PIZZA ELITE 1 VANO SERIE 80**

Il costruttore si riserva il diritto di apportare modifiche ai prodotti senza preavviso.  
The manufacturer reserves the rights to modify its products without prior notice.  
Le constructeur se réserve le droit d'apporter des modifications aux produits sans préavis.  
Veränderungen an den Produkten können vom Hersteller ohne Vorankündigung vorgenommen

ILSA  
S.p.A

Via Ferrovia, 31  
I - 31010 Castello Roganzuolo  
di San Fior (Tv)  
ITALY

Tel. +39 0438 4905  
Fax +39 0438 400791





**TAVOLI PIZZA ELITE - VENTILATI TN**  
 ELITE PIZZA PREPARATION TABLE - VENTILATED TN  
 TABLES DE PREPARATION PIZZA ELITE - VENTILEES TN  
 ELITE GEKÜHLTER VORBEREITUNGSTISCH -  
 UMLUFTKÜHLUNG TN

**PIZZA  
 ELITE  
 80**

02/2012 - 00

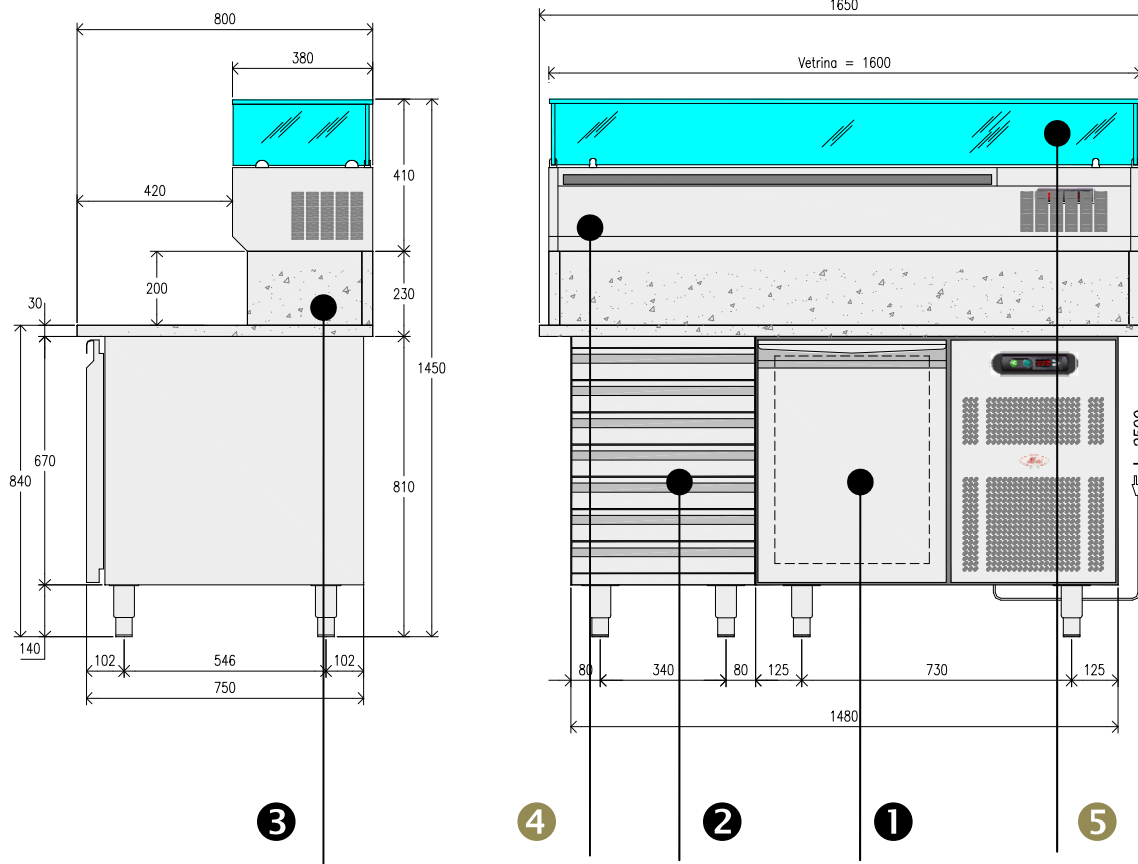

BCPZ3015	
1	TRPZ3020
2	CPZ0005
3	PGPZ2055-SI 1650 x 800 x 30 (200)
4	VR381021 1600 x 380
5	KVPC0008

**BCPZ3015 - BANCO PIZZA ELITE 1 VANO SERIE 80**

Il costruttore si riserva il diritto di apportare modifiche ai prodotti senza preavviso.  
 The manufacturer reserves the rights to modify its products without prior notice.  
 Le constructeur se réserve le droit d'apporter des modifications aux produits sans préavis.  
 Veränderungen an den Produkten können vom Hersteller ohne Vorankündigung vorgenommen

ILSA  
 S.p.A

Via Ferrovia, 31  
 I - 31010 Castello Roganzuolo  
 di San Fior (Tv)  
 ITALY

Tel. +39 0438 4905  
 Fax +39 0438 400791





**TAVOLI PIZZA ELITE - VENTILATI TN**  
 ELITE PIZZA PREPARATION TABLE - VENTILATED TN  
 TABLES DE PREPARATION PIZZA ELITE - VENTILEES TN  
 ELITE GEKÜHLTER VORBEREITUNGSTISCH -  
 UMLUFTKÜHLUNG TN

**PIZZA  
 ELITE  
 80**

02/2012 - 00

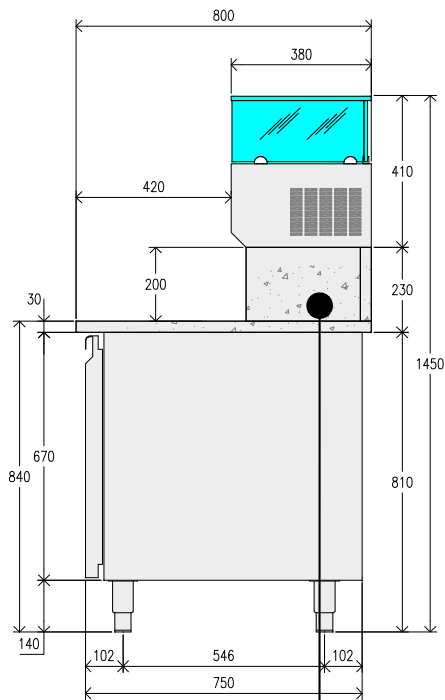

**3**

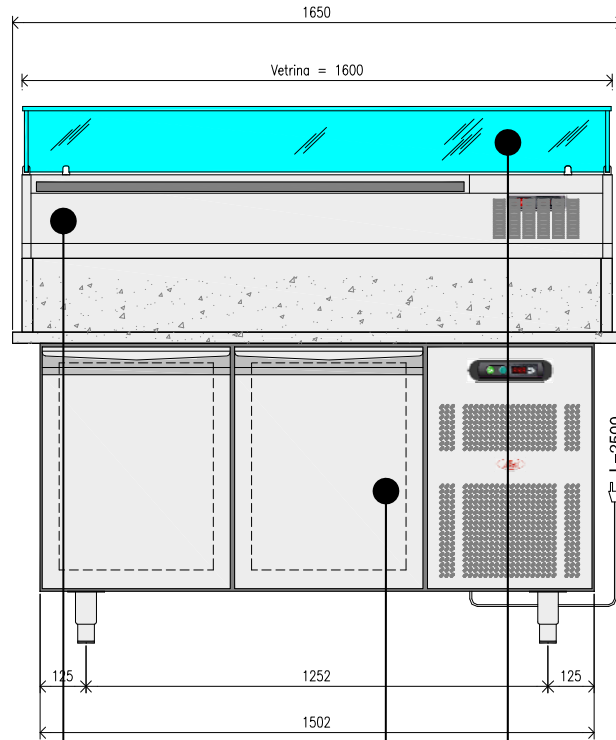

**4**

**1**

**5**

BCPZ3013	
1	TRPZ3001
2	---
3	PGPZ2055-SI 1650 x 800 x 30 (200)
4	VR381021 1600 x 380
5	KVPC0008

**BCPZ3013 - BANCO PIZZA ELITE 2 VANI SERIE 80**

Il costruttore si riserva il diritto di apportare modifiche ai prodotti senza preavviso.  
 The manufacturer reserves the rights to modify its products without prior notice.  
 Le constructeur se réserve le droit d'apporter des modifications aux produits sans préavis.  
 Veränderungen an den Produkten können vom Hersteller ohne Vorankündigung vorgenommen

**ILSA  
 S.p.A**

Via Ferrovia, 31  
 I - 31010 Castello Roganzuolo  
 di San Fior (Tv)  
 ITALY

Tel. +39 0438 4905  
 Fax +39 0438 400791





**TAVOLI PIZZA ELITE - VENTILATI TN**  
 ELITE PIZZA PREPARATION TABLE - VENTILATED TN  
 TABLES DE PREPARATION PIZZA ELITE - VENTILEES TN  
 ELITE GEKÜHLTER VORBEREITUNGSTISCH -  
 UMLUFTKÜHLUNG TN

**PIZZA  
 ELITE  
 80**

02/2012 - 00

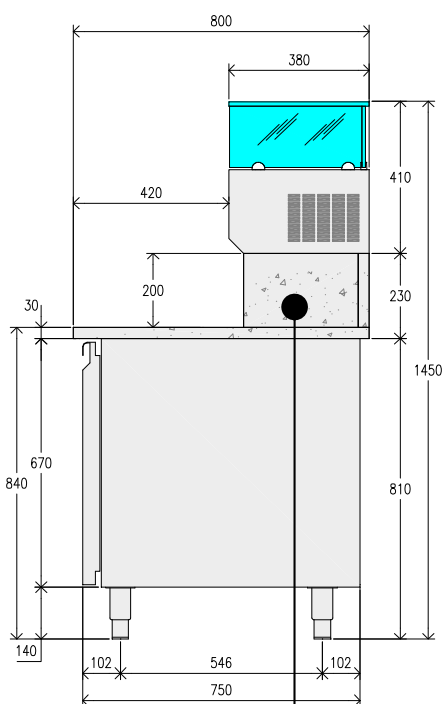

3

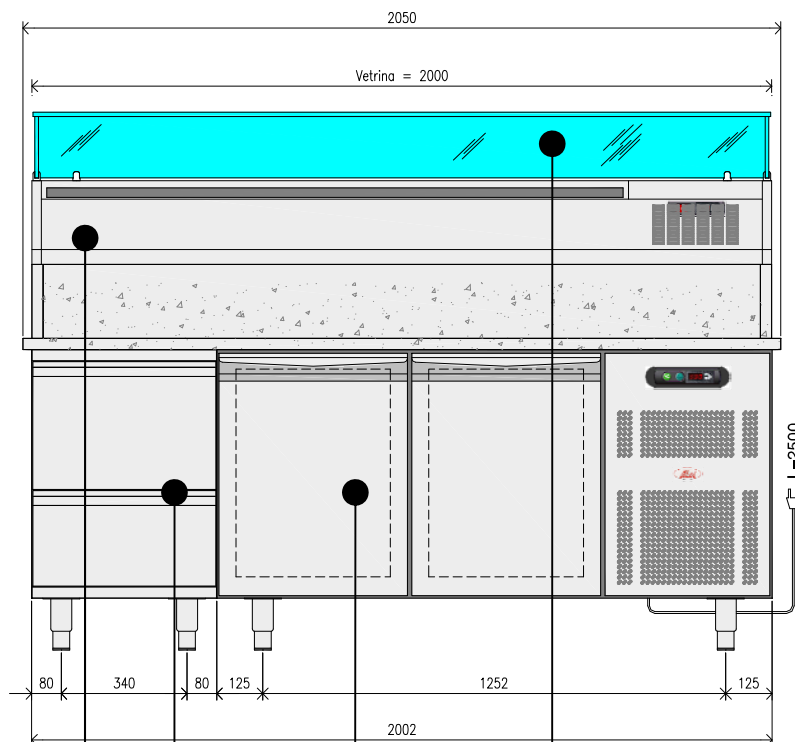

4

2

1

5

BCPZ3017	
1	TRPZ3001
2	CPZ0011
3	PGPZ2057-SI 2050 x 800 x 30 (200)
4	VR381023 2050 x 380
5	KVPC0010

**BCPZ3017 - BANCO PIZZA ELITE 2 VANI SERIE 80**

Il costruttore si riserva il diritto di apportare modifiche ai prodotti senza preavviso.  
 The manufacturer reserves the rights to modify its products without prior notice.  
 Le constructeur se réserve le droit d'apporter des modifications aux produits sans préavis.  
 Veränderungen an den Produkten können vom Hersteller ohne Vorankündigung vorgenommen

ILSA  
 S.p.A

Via Ferrovia, 31  
 I - 31010 Castello Roganzuolo  
 di San Fior (Tv)  
 ITALY

Tel. +39 0438 4905  
 Fax +39 0438 400791





**TAVOLI PIZZA ELITE - VENTILATI TN**  
 ELITE PIZZA PREPARATION TABLE - VENTILATED TN  
 TABLES DE PREPARATION PIZZA ELITE - VENTILEES TN  
 ELITE GEKÜHLTER VORBEREITUNGSTISCH -  
 UMLUFTKÜHLUNG TN

**PIZZA  
 ELITE  
 80**

02/2012 - 00

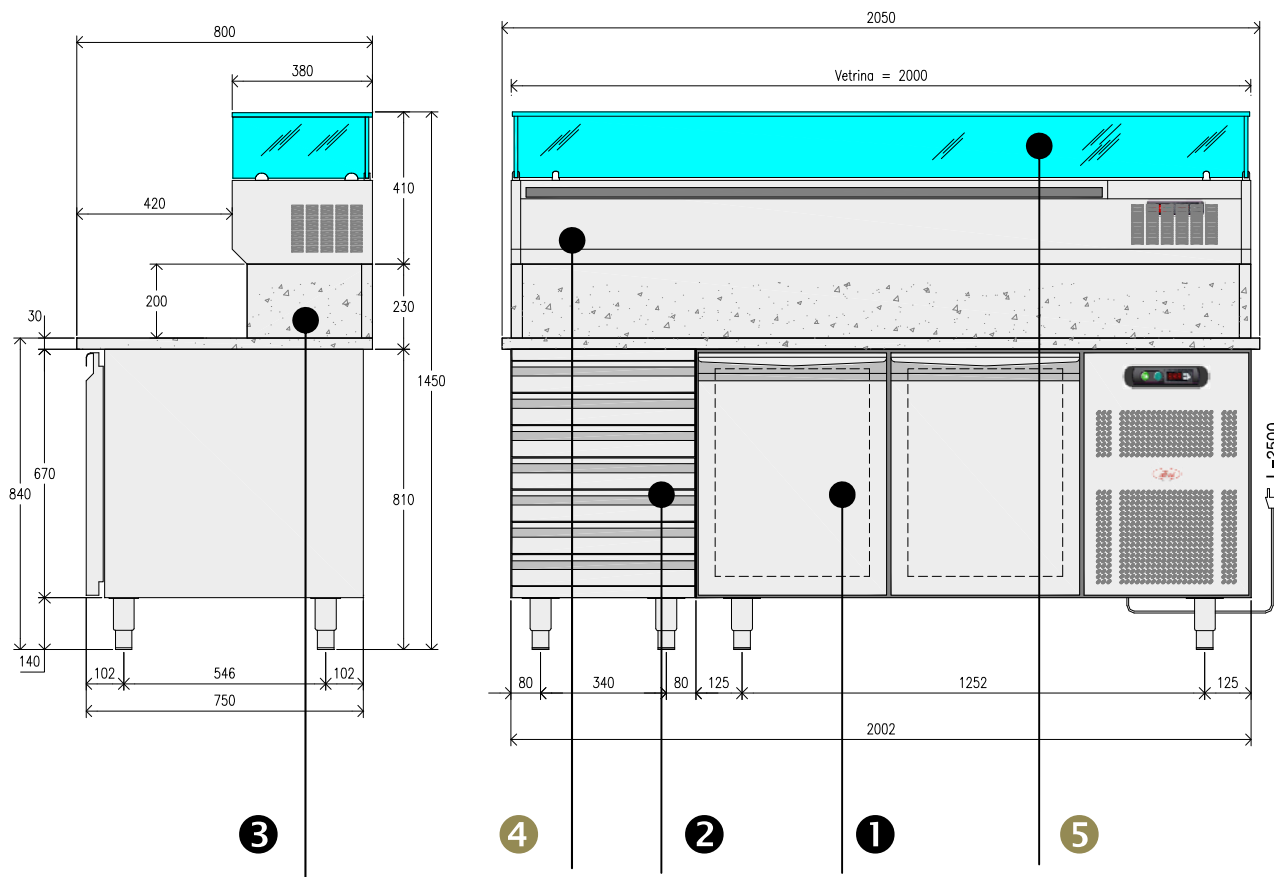

BCPZ3018	
1	TRPZ3021
2	CPZ0005
3	PGPZ2057-SI 2050 x 800 x 30 (200)
4	VR381023 2050 x 380
5	KVPC0010

**BCPZ2018 - BANCO PIZZA ELITE 2 VANI SERIE 80**

Il costruttore si riserva il diritto di apportare modifiche ai prodotti senza preavviso.  
 The manufacturer reserves the rights to modify its products without prior notice.  
 Le constructeur se réserve le droit d'apporter des modifications aux produits sans préavis.  
 Veränderungen an den Produkten können vom Hersteller ohne Vorankündigung vorgenommen

**ILSA  
 S.p.A**

Via Ferrovia, 31  
 I - 31010 Castello Roganzuolo  
 di San Fior (Tv)  
 ITALY

Tel. +39 0438 4905  
 Fax +39 0438 400791





**TAVOLI PIZZA ELITE - VENTILATI TN**  
 ELITE PIZZA PREPARATION TABLE - VENTILATED TN  
 TABLES DE PREPARATION PIZZA ELITE - VENTILEES TN  
 ELITE GEKÜHLTER VORBEREITUNGSTISCH -  
 UMLUFTKÜHLUNG TN

**PIZZA  
 ELITE  
 80**

02/2012 - 00

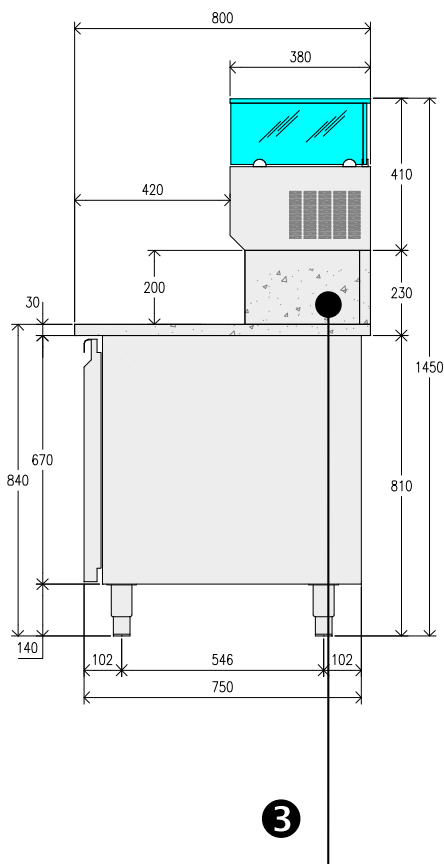

**3**

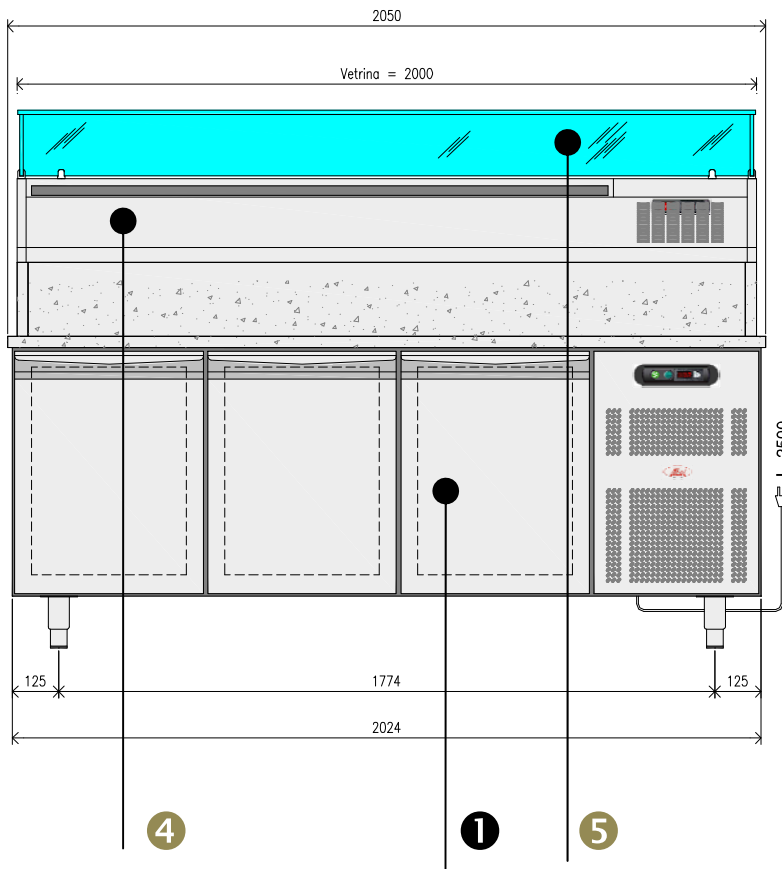

**4**

**1**

**5**

<b>BCPZ3016</b>	
<b>1</b>	<b>TRPZ022</b>
<b>2</b>	<b>---</b>
<b>3</b>	<b>PGPZ2057-SI 2050 x 800 x 30 (200)</b>
<b>4</b>	<b>VR381023 2050 x 380</b>
<b>5</b>	<b>KVPC0010</b>

**BCPZ3016 - BANCO PIZZA ELITE 3 VANI SERIE 80**

Il costruttore si riserva il diritto di apportare modifiche ai prodotti senza preavviso.  
 The manufacturer reserves the rights to modify its products without prior notice.  
 Le constructeur se réserve le droit d'apporter des modifications aux produits sans préavis.  
 Veränderungen an den Produkten können vom Hersteller ohne Vorankündigung vorgenommen

**ILSA  
 S.p.A**

Via Ferrovia, 31  
 I - 31010 Castello Roganzuolo  
 di San Fior (Tv)  
 ITALY

Tel. +39 0438 4905  
 Fax +39 0438 400791





**TAVOLI PIZZA ELITE - VENTILATI TN**  
 ELITE PIZZA PREPARATION TABLE - VENTILATED TN  
 TABLES DE PREPARATION PIZZA ELITE - VENTILEES TN  
 ELITE GEKÜHLTER VORBEREITUNGSTISCH -  
 UMLUFTKÜHLUNG TN

**PIZZA  
 ELITE  
 80**

02/2012 - 00

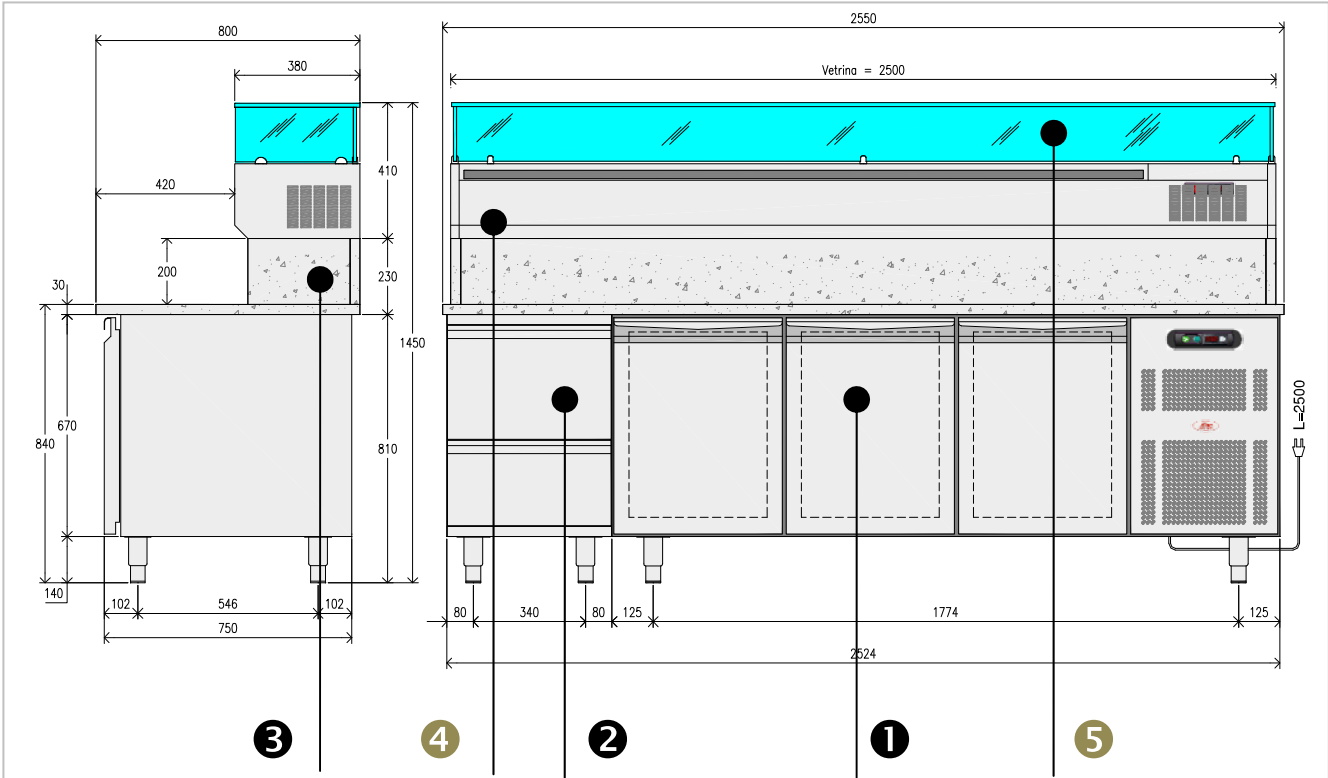

BCPZ3019	
1	TRPZ3022
2	CPZ0011
3	PGPZ2060-SI 2550 x 800 x 30 (200)
4	VR381027 2500 x 380
5	KVPC0013

**BCPZ3019 - BANCO PIZZA ELITE 3 VANI SERIE 80**

Il costruttore si riserva il diritto di apportare modifiche ai prodotti senza preavviso.  
 The manufacturer reserves the rights to modify its products without prior notice.  
 Le constructeur se réserve le droit d'apporter des modifications aux produits sans préavis.  
 Veränderungen an den Produkten können vom Hersteller ohne Vorankündigung vorgenommen

ILSA  
 S.p.A

Via Ferrovia, 31  
 I - 31010 Castello Roganzuolo  
 di San Fior (Tv)  
 ITALY

Tel. +39 0438 4905  
 Fax +39 0438 400791







**TAVOLI PIZZA ELITE - VENTILATI TN**  
 ELITE PIZZA PREPARATION TABLE - VENTILATED TN  
 TABLES DE PREPARATION PIZZA ELITE - VENTILEES TN  
 ELITE GEKÜHLTER VORBEREITUNGSTISCH -  
 UMLUFTKÜHLUNG TN

**PIZZA  
 ELITE  
 80**

02/2012 - 00

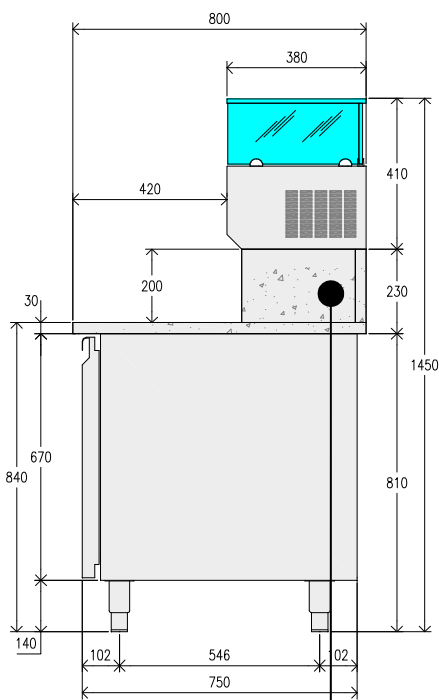

3

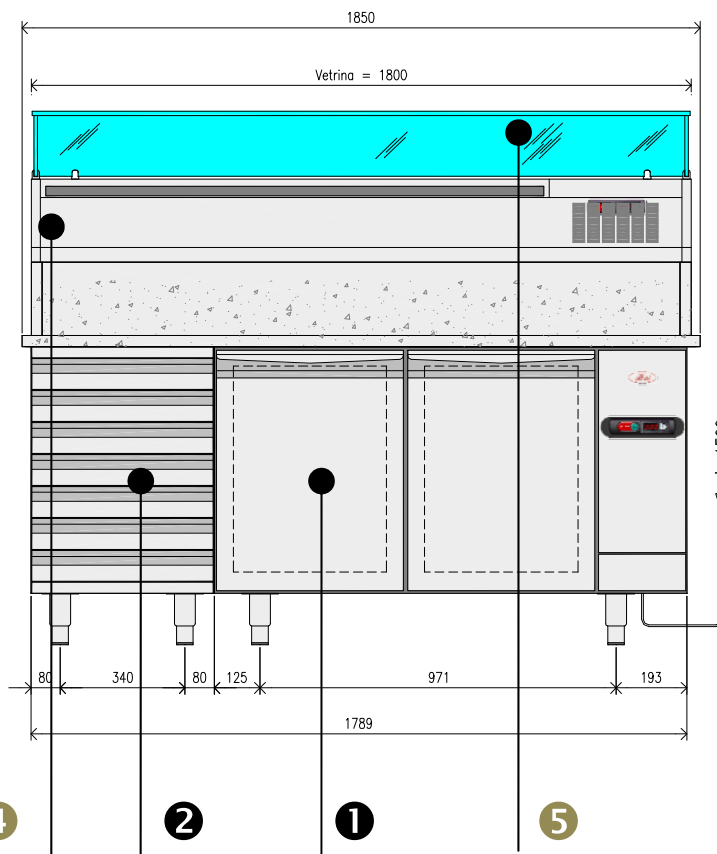

4

2

1

5

BCPZ3020	
1	TRPZ3023
2	CPZ0005
3	PGPZ2056-SI 1850 x 800 x 30 (200)

4	VR381022 1800 x 380
5	KVPC0009

**BCPZ3020 - BANCO PIZZA ELITE 2 VANI REMOTO SERIE 80**

Il costruttore si riserva il diritto di apportare modifiche ai prodotti senza preavviso.  
 The manufacturer reserves the rights to modify its products without prior notice.  
 Le constructeur se réserve le droit d'apporter des modifications aux produits sans préavis.  
 Veränderungen an den Produkten können vom Hersteller ohne Vorankündigung vorgenommen

ILSA  
 S.p.A

Via Ferrovia, 31  
 I - 31010 Castello Roganzuolo  
 di San Fior (Tv)  
 ITALY

Tel. +39 0438 4905  
 Fax +39 0438 400791





**TAVOLI PIZZA ELITE - VENTILATI TN**  
 ELITE PIZZA PREPARATION TABLE - VENTILATED TN  
 TABLES DE PREPARATION PIZZA ELITE - VENTILEES TN  
 ELITE GEKÜHLTER VORBEREITUNGSTISCH -  
 UMLUFTKÜHLUNG TN

**PIZZA  
 ELITE  
 80**

02/2012 - 00

Modello - Model - Model - Gerätetyp	BCPZ3014	BCPZ3015	BCPZ3013	BCPZ3017	
<b>Porte</b> - Doors - Portes - Türen	1 Door	1 Door	2 Doors	2 Doors	
<b>Tavolo</b> - Tables - Tables - Umluftkühlung	<b>TRPZ3020</b>	<b>TRPZ3020</b>	<b>TRPZ3021</b>	<b>TRPZ3021</b>	
<b>Cassettiera</b> - Set of Drawers Elements Tirirs - Schubladenfach	<b>CPZ0011</b>	<b>CPZ0005</b>	- - -	<b>CPZ0011</b>	
<b>Piano in granito</b> - Top - Plan	<b>PGPZ2055-SI</b> 1650 x 800 x 30 (200)	<b>PGPZ2055-SI</b> 1650 x 800 x 30 (200)	<b>PGPZ2055-SI</b> 1650 x 800 x 30 (200)	<b>PGPZ2057-SI</b> 2050 x 800 x 30 (200)	
<b>Range</b>	-2°C...+8°C	-2°C...+8°C	-2°C...+8°C	-2°C...+8°C	
<b>Funzionamento</b> - Operating Mode Mode de fonctionnement - Betriebsmodus	Ⓛ V	Ⓛ V	Ⓛ V	Ⓛ V	
<b>Capacità lorda</b> - Gross Capacity Capacité brute - Bruttovolumen	152	152	342	342	
<b>Dimensioni esterne</b> - External Dimension Dimensions externes - ußenabmessungen	Lunghezza - Width - Largeur - Breite mm	1650	1650	2050	
	Profondità - Depth - Profondeur - Tiefe mm	800	800	800	
	Altezza - Height - Hauteur - Höhe mm	810 + 230	810 + 230	810 + 230	810 + 230
<b>Dotazione Standard</b> - Standard Equipment Equipement standard - Standardausstattung	1 coppie guide per porta - 1 pairs of slides per door 1 couples des glissières chaque porte - 1 Paar Führungen pro Tür				
<b>Sbrinamento</b> - Defrost - Dégivrages - Abtauen	Type	Gas caldo - Hot gas - Gaz chaude - Heissem Gas			
	N° Defrost in 24 hrs.	3	3	3	
	Evaporazione acqua sbrinamento Evaporation of defrost water Evaporation eau de dégivrage Tauwasserverdunstung	Gas caldo - Hot gas - Gaz chaude - Heissem Gas			
<b>Potenza Compressore</b> - Total Power Puissance - Leistung	HP	1/4	1/4	1/4	1/4
<b>Potenza frigorifera</b> - Refrigerant Power Puissance frigorifique - Kälteleistung	watt	550	550	550	550
<b>Refrigerante</b> - Refrigerant type Réfrigérant type - Kältemitteltyp		R404A	R404A	R404A	R404A
<b>Quantità di refrigerante</b> - Refrigerant quantity Quantité de réfrigérant - Kältemittelmenge	gr	<b>330</b>	<b>330</b>	<b>330</b>	<b>330</b>
<b>Potenza assorbita</b> - Total Power Puissance - Leistung	watt	360 - 2,4	360 - 2,4	360 - 2,4	360 - 2,4
<b>Tensione alimentazione</b> - Supply Voltage Tension d'alimentation - Anschlussspannung	V	230V~ 50Hz 1+N	230V~ 50Hz 1+N	230V~ 50Hz 1+N	230V~ 50Hz 1+N
<b>Vetrina (non compresa)</b>	<b>VR381021 + KVPC0008</b> 1600 x 380	<b>VR381021 + KVPC0008</b> 1600 x 380	<b>VR381021 + KVPC0008</b> 1600 x 380	<b>VR381023 + KVPC0010</b> 2000 x 380	
Ⓛ S = / V = Ventilato - Ventilated - Ventile - Umluftkühlung					
Ⓛ ● = Dotazione di serie - Standard equipment - Dotation standard - Serien Ausstattung □ = Optional					



**TAVOLI PIZZA ELITE - VENTILATI TN**  
 ELITE PIZZA PREPARATION TABLE - VENTILATED TN  
 TABLES DE PREPARATION PIZZA ELITE - VENTILEES TN  
 ELITE GEKÜHLTER VORBEREITUNGSTISCH -  
 UMLUFTKÜHLUNG TN

**PIZZA  
 ELITE  
 80**

02/2012 - 00

Modello - Model - Model - Gerätetyp	BCPZ3018	BCPZ3016	BCPZ3019	BCPZ3020		
<b>Porte</b> - Doors - Portes - Türen	2 Doors	3 Doors	3 Doors	2 Doors		
<b>Tavolo</b> - Tables - Tables - Umluftkühlung	<b>TRPZ3021</b>	<b>TRPZ3022</b>	<b>TRPZ3022</b>	<b>TRPZ3023</b>		
<b>Cassettiera</b> - Set of Drawers Elements Tiroirs - Schubladenfach	<b>CPZ0005</b>	- - -	<b>CPZ0011</b>	<b>CPZ0005</b>		
<b>Piano in granito</b> - Top - Plan	<b>PGPZ2057-SI</b> 2050 x 800 x 30 (200)	<b>PGPZ2057-SI</b> 2050 x 800 x 30 (200)	<b>PGPZ2060-SI</b> 2550 x 800 x 30 (200)	<b>PGPZ2056-SI</b> 1850 x 800 x 30 (200)		
<b>Range</b>	-2°C...+8°C	-2°C...+8°C	-2°C...+8°C	-2°C...+8°C		
<b>Funzionamento</b> - Operating Mode Mode de fonctionnemen - Betriebsmodus	<b>V</b>	<b>V</b>	<b>V</b>	<b>V</b>		
<b>Capacità lorda</b> - Gross Capacity Capacité brute - Bruttovolumen	342	532	532	342		
<b>Dimensioni esterne</b> - External Dimension Dimensions externes - ußenabmessungen	1 coppie guide per porta - 1 pairs of slides per door 1 couples des glissières chaque porte - 1 Paar Führungen pro Tür					
	Lunghezza - Width - Largeur - Breite	mm	2050	2050	2550	1850
	Profondità - Depth - Profondeur - Tiefe	mm	800	800	800	800
	Altezza - Height - Hauteur - Höhe	mm	810 + 230	810 + 230	810 + 230	810 + 230
<b>Sbrinamento</b> - Defrost - Dégivrages - Abtauen	1 coppie guide per porta - 1 pairs of slides per door 1 couples des glissières chaque porte - 1 Paar Führungen pro Tür					
Type	Gas caldo - Hot gas - Gaz chaude - Heissem Gas			Elettrico - Electric		
N° Defrost in 24 hrs.	3	3	3	3		
Evaporazione acqua sbrinamento Evaporation of defrost water Evaporation eau de dégivrage Tauwasserverdunstung	Gas caldo - Hot gas - Gaz chaude - Heissem Gas			Manual		
<b>Potenza compressore</b> - Total Power Puissance - Leistung	HP	1/4	1/4	1/4		
<b>Potenza frigorifera</b> - Refrigerant Power Puissance frigorifique - Kälteleistung	watt	550	550	550	550	
<b>Refrigerante</b> - Refrigerant type Réfrigérant type - Kältemitteltyp		R404A	R404A	R404A	R404A	
<b>Quantità di refrigerante</b> - Refrigerant quantity Quantité de réfrigérant - Kältemittelmenge	gr	<b>330</b>	<b>330</b>	<b>330</b>		
<b>Potenza assorbita</b> - Total Power Puissance - Leistung	watt	360 - 2,4	360 - 2,4	360 - 2,4		
<b>Tensione alimentazione</b> - Supply Voltage Tension d'alimentation - Anschlussspannung	V	230V~ 50Hz 1+N	230V~ 50Hz 1+N	230V~ 50Hz 1+N		
<b>Vetrina</b> (non compresa)	<b>VR381023 + KVPC0010</b> 2000 x 380	<b>VR381023 + KVPC0010</b> 2000 x 380	<b>VR381027 + KVPC0013</b> 2500 x 380	<b>VR381022 + KVPC0009</b> 1800 x 380		
① S = / V = Ventilato - Ventilated - Ventile - Umluftkühlung						
② ● = Dotazione di serie - Standard equipment - Dotation standard - Serien Ausstattung □ = Optional						