

# Robatayaki with elevating system RM SE 115



## FEATURES

### WHAT IS A ROBATAYAKI?

Inspired by the centuries-old Japanese style of cooking Robatayaki, or often known as Robata, we have created the new Mibrasa® Robatayaki.

A multi-tier open charcoal grill equipped with accessories to perform a range of cooking techniques using grills, Teppanyaki hot plates or skewers. Robata grilling lends to an array of foods from meat, fish, seafood and vegetables, imparting light smoky aromas and flavors we seek in grill cooking.

Originating from the Japanese tea ceremony, which overtime found its way to the north Japanese fishermen utilizing this method to keep food hot while out at sea for long periods. The evolution of the Robatayaki has brought it into the modern kitchen, where chefs prepare the food and display their showmanship in front of diners allowing them to take part in the entire cooking experience.

### QUALITY AND CONSTRUCTION

The MIBRASA® Robatayaki is manufactured with steels of the latest technology following the most rigorous quality controls.

## TECHNICAL INFORMATION

Fire up time <sup>1</sup>	30 min-average
Cooking temperature	250 °C
Initial charcoal load <sup>1</sup>	7 kg
Charcoal load duration <sup>2</sup>	5 h
Equivalent power*	2 kW
Exhaust rate	3000 m <sup>3</sup> /h
Max. no. grills/level	3
Net weight <sup>3</sup>	177 kg
Crated weight <sup>3</sup>	240 kg
Crated size (WxDxH)	1350 x 550 x 1200 mm

\*Approximate data

1. Consult instruction manual

2. Will vary depending on quality of charcoal

3. Weight with accessories included

## GRILL DIMENSIONS



## INCLUDED ACCESSORIES

- Top grill (3) [RTG]
- Lower grill (3) [LTG]
- Support bars (4)
- Ember poker [PK]
- Ash shovel [PALA]
- Mibrasa tongs [TG]
- Grill brush [CEP]
- Mibrasa ecofire firelighters [FL]

## OPTIONAL ACCESSORIES

- Top mesh grill [TGM]
- Lower mesh grill [LGM]
- Flat top Teppanyaki griddle [FTTG]
- Perforated Teppanyaki griddle [PTG]
- Espeto kit [KITESPRM115]
- Gastronorm support kit [SGN115]
- Robatayaki stand [S115]
- Robatayaki drop-leaf stand [DLS115]
- Lid for end of service [TAPARM115]

Specifications and design are subject to change without notice.

## QUALITY GUARANTEE





# Robotayaki with elevating system RM SE 115

FRONT VIEW

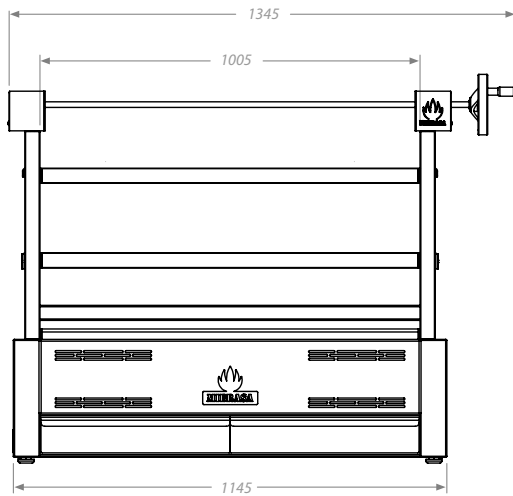

SIDE VIEW

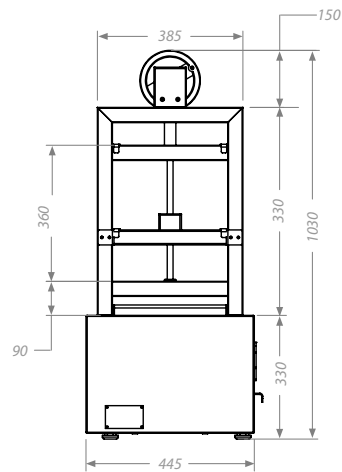

TOP VIEW

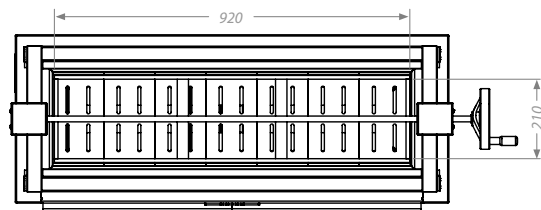

**RM SE (Mibrasa Robotayaki with elevating system)**

With an incorporated elevating system, designed and patented by Mibrasa® enabling height adjustments between the grill and hot coals to provide the chef with total control allowing them to cook with more efficiency.

**GRILL TYPES**

Grill

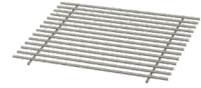

Mesh grill

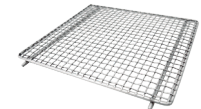

Flat top Teppanyaki griddle



Perforated Teppanyaki griddle



Revit drawings available on request at [mibrasa@mibrasa.com](mailto:mibrasa@mibrasa.com)

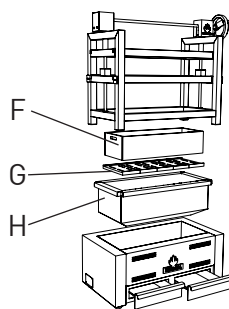
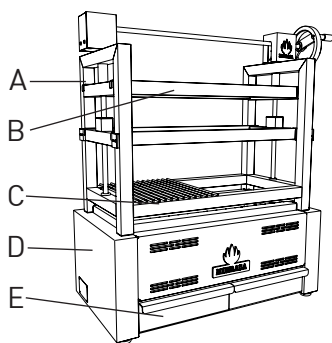

A	SE Structure
B	SE Support bars
C	Grill
D	Main body
E	Ash collector
F	Burning pit
G	Charcoal grids
H	Interior body

**INSTALLATION GUIDELINES AND SAFETY STANDARDS**

Recommended installation height	800 mm
Clearances to construction/other appliances from the Robotayaki	76 mm
Clearances of flammable materials from the Robotayaki	300 mm
Clearance of workspace from front of the Robotayaki	700 mm



\*It is recommended to use a lifting device to lift the Robotayaki and place on the countertop/stand.

Consult Robotayaki instruction manual for further information.

Specifications and design are subject to change without notice.